

## G170-19 Concealed Hinge

170° opening · 19 mm overlay · Overlay 15 ~ 20 mm  
Door thickness 15 ~ 20 mm

### Features

- Opening angle can be adjusted 140° ~ 170° degrees by turning the adjustment dial on the hinge
- Passed 40,000 life cycle test

### Recommended Screws

- M4 raised countersunk head screw

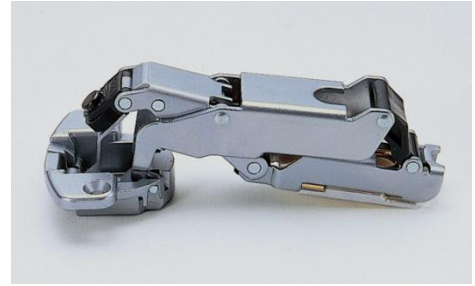

Above picture shows concealed hinge + mounting plate (sold separately)

Part No.	Type	Material	Finish
G170-34/19	Without Catch	Body: Steel Cup: Zinc Alloy (ZDC)	Satin Chrome
G170-C34/19	With Catch		

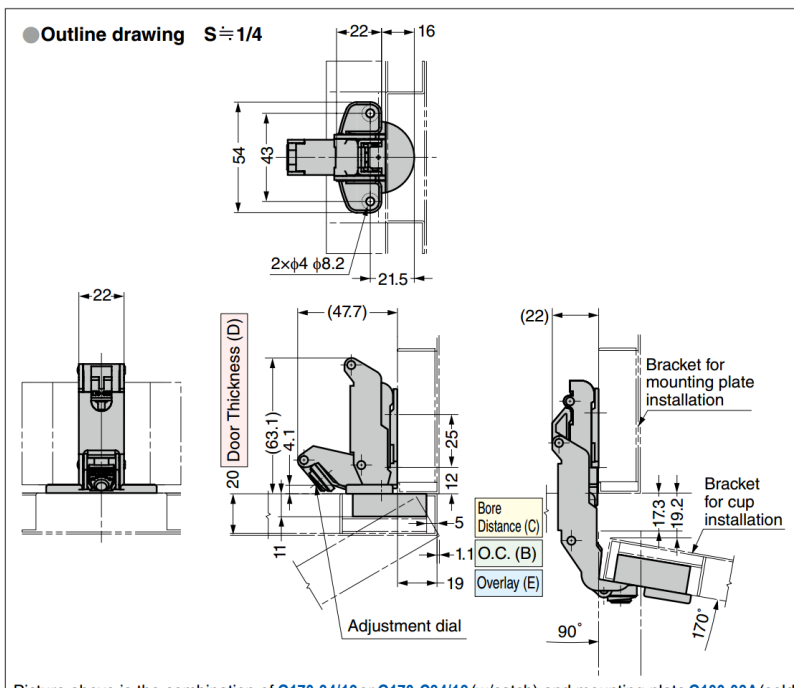

Picture above is the combination of G170-34/19 or G170-C34/19 (w/catch) and mounting plate G100-03A (sold separately).

### [Bore Distance (C)]

Table-1

Bore Distance (C)	3	4	5	6
Overlay (E)	17	18	19	20

For standard type shown in the table above mounting plate 0mm thickness.

Turning the overlay adjustment screw or using spacer (2mm thickness) to adjust overlay (Max. -3mm).

### [Opening Clearance (O.C.)]

Clearances for door edge O.C. (A) and hinge side O.C. (B) are necessary. O.C. (A) and (B) change depending on door thickness and bore distance (C). Refer to locus chart and tables below when designing cabinets.

### [O.C.(B)]

Table-2

Door Thickness (D)	Bore Distance (C)			
	3	4	5	6
15	0	0	0	0
16	0	0	0	0
17	0.1	0.1	0.1	0.1
18	0.1	0.1	0.1	0.1
19	1.1	0.8	0.3	0.1
20	2.5	1.7	1.1	0.6
21※	3.5	2.7	2.0	1.5
22※	4.5	3.7	2.9	2.3

O.C. (B)

※The above table is O.C. (B) for 0-90° opening. Please refer to the locus chart if door thickness is over 20mm. (O.C. (B) can be made smaller by R chamfering (round chamfer) and C chamfering (chamfer plane) on the door).

### [O.C.(A)]

Table-3

Door Thickness (D)	O.C. (A)		
	Door Width 300	Door Width 400	Door Width 500
15	0.7	0.6	0.5
20	0.7	0.6	0.5
22	0.7	0.6	0.5

## G170-9 Concealed Hinge

170° opening · 9 mm overlay · Overlay 5 ~ 10 mm  
Door thickness 15 ~ 20 mm

### Features

- Opening angle can be adjusted 140° ~ 170° degrees by turning the adjustment dial on the hinge
- Passed 40,000 life cycle test

### Recommended Screws

- M4 raised countersunk head screw

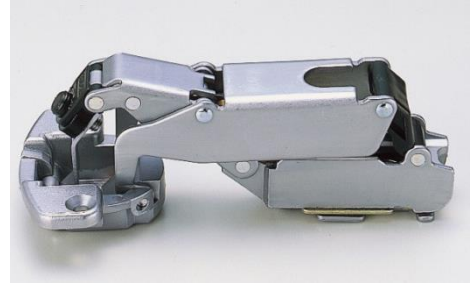

Above picture shows concealed hinge + mounting plate (sold separately)

Part No.	Type	Material	Finish
G170-34/9	Without Catch	Zinc Alloy (ZDC)	Satin Chrome
G170-C34/9	With Catch		

### ● Outline drawing S ≐ 1/4

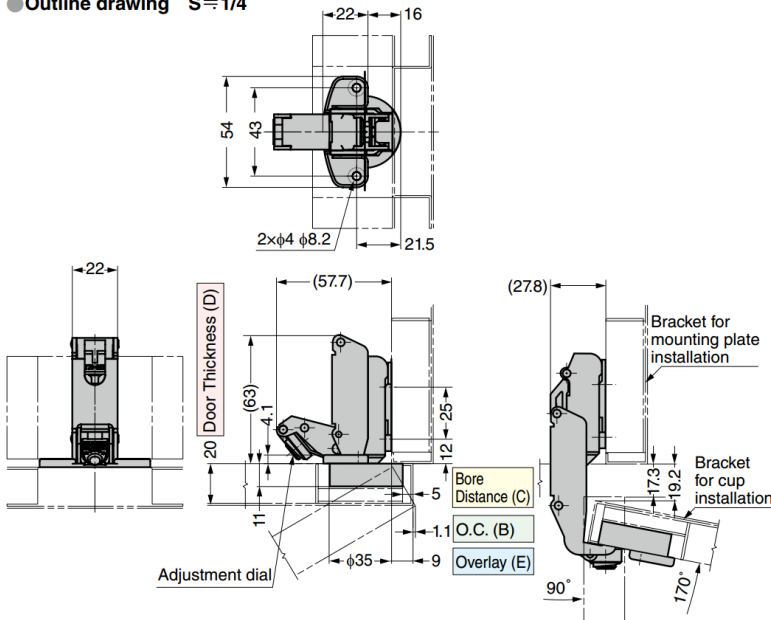

Picture above is the combination of G170-34/9 or G170-C34/9(w/catch) and mounting plate G100-03A (sold separately).

### ● Locus chart S ≐ 1/4

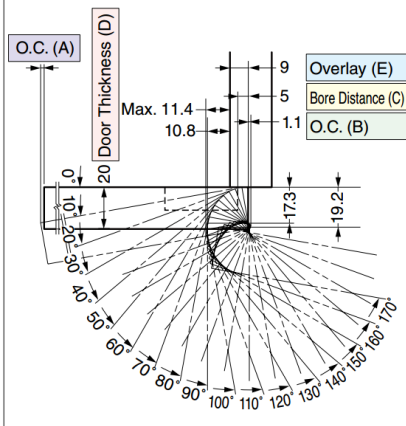

### ● Cut Out Dimensions For metal door

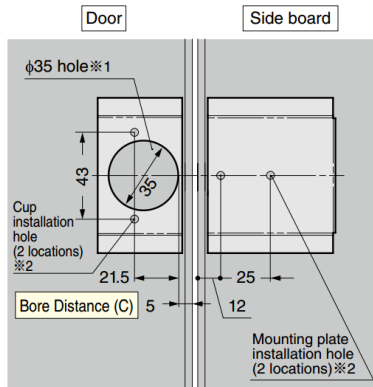

- ※1: Support the cup bottom at position of 11mm deep.
- ※2: Internal threads need to be made by welding nut or burring.

### [ Bore Distance (C) ]

Table-1

Bore Distance (C)	3	4	5	6
Overlay (E)	7	8	9	10

For standard type shown in the table above mounting plate 0mm thickness.

Turning the overlay adjustment screw or using spacer (2mm thickness) to adjust overlay (Max. -3mm).

### [ Opening Clearance (O.C.) ]

Clearances for door edge O.C. (A) and hinge side O.C. (B) are necessary. O.C. (A) and (B) change depending on door thickness and bore distance (C). Refer to locus chart and tables below when designing cabinets.

### [ O.C.(B) ]

Table-2

Door Thickness (D)	Bore Distance (C)			
	3	4	5	6
15	0	0	0	0
16	0	0	0	0
17	0	0	0	0
18	0.1	0.1	0	0
19	1.0	0.6	0.2	0
20	2.3	1.7	1.1	0.6
21※	3.5	2.6	2.0	1.5
22※	4.4	3.5	2.9	2.2
O.C. (B)				

※The above table is O.C. (B) for 0-90° opening. Please refer to the locus chart if door thickness is over 20mm. (O.C. (B) can be made smaller by R chamfering (round chamfer) and C chamfering (chamfer plane) on the door).

### [ O.C.(A) ]

Table-3

Door Thickness (D)	O.C. (A)		
	Door Width 300	Door Width 400	Door Width 500
15	0.7	0.5	0.5
20	0.7	0.5	0.5
22	0.7	0.5	0.5

## G170-0 Concealed Hinge

170° opening · Inset  
Door thickness 15 ~ 20 mm

### Features

- Opening angle can be adjusted 140° ~ 170° degrees by turning the adjustment dial on the hinge
- Passed 40,000 life cycle test

### Recommended Screws

- M4 raised countersunk head screw

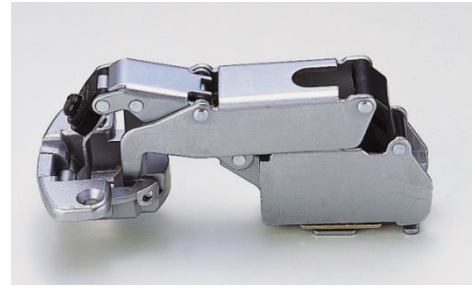

Above picture shows concealed hinge + mounting plate (sold separately)

Part No.	Type	Material	Finish
G170-34/0	Without Catch	Zinc Alloy (ZDC)	Satin Chrome
G170-C34/0	With Catch		

### ● Outline drawing S ≒ 1/4

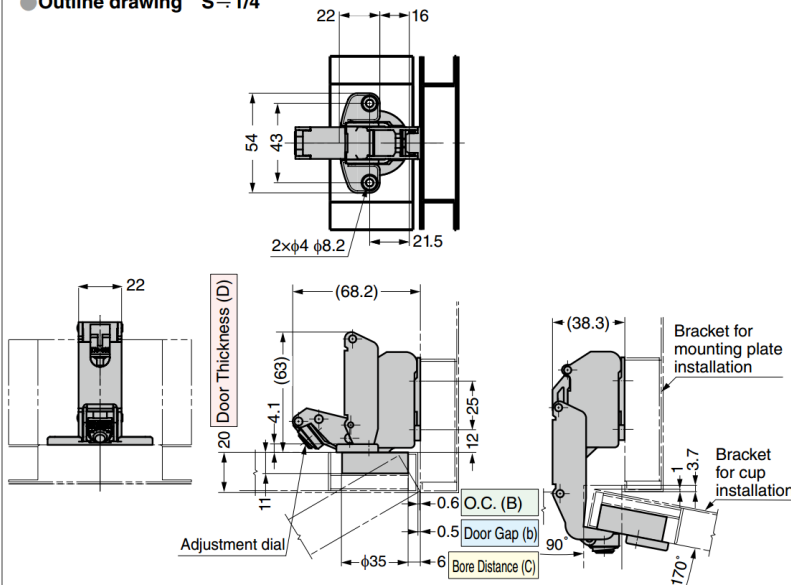

Picture above is the combination of G170-34/0 or G170-C34/0 (w/catch) and mounting plate G100-03A (sold separately).

### ● Locus chart S ≒ 1/4

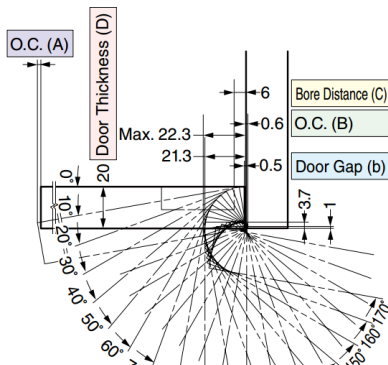

### ● Cut Out Dimensions For metal door

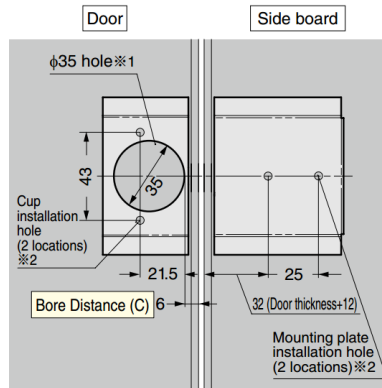

- ※1: Support the cup bottom at position of 11mm deep.
- ※2: Internal threads need to be made by welding nut or burring.

### [Bore Distance (C)]

Table-1

Bore Distance (C)	3	4	5	6
Door Gap (b)	3.5	2.5	1.5	0.5

For standard type shown in the table above mounting plate 0mm thickness.

Turning the overlay adjustment screw or using spacer (2mm thickness) to adjust overlay (Max. -3mm).

### [Opening Clearance (O.C.)]

Clearances for door edge O.C. (A) and hinge side O.C. (B) are necessary. O.C. (A) and (B) change depending on door thickness and bore distance (C). Refer to locus chart and tables below when designing cabinets.

### [O.C.(B)]

Table-2

Door Thickness (D)	Bore Distance (C)			
	3	4	5	6
15	0	0	0	0
16	0	0	0	0
17	0	0	0	0
18	0.1	0.1	0	0
19	1.0	0.6	0.2	0
20	2.3	1.7	1.1	0.6
21※	3.5	2.6	2.0	1.5
22※	4.4	3.5	2.9	2.2

O.C. (B)

※The above table is O.C. (B) for 0-90° opening. Please refer to the locus chart if door thickness is over 20mm.

(O.C. (B) can be made smaller by R chamfering (round chamfer) and C chamfering (chamfer plane) on the door.)

### [O.C.(A)]

Table-3

Door Thickness (D)	O.C. (A)		
	Door Width 300	Door Width 400	Door Width 500
15	0.7	0.5	0.5
20	0.7	0.5	0.5
22	0.7	0.5	0.5

## G100-01 Mounting Plate

### Features

- Standard height: 0 mm
- Value of H: Door thickness + 17 mm in use of INSET type (Door thickness + 12 mm in use of INSET type of GH160 or G170 hinge)

### Recommended Screws

- Size 3.5 tapping screw or wood screw (do not use countersunk head screws)

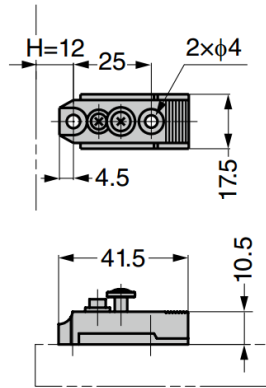

Part No.	Material	Colour
G100-01	PA	Ivory

## G100-03 Mounting Plate

### Features

- Standard height: 0 mm
- Value of H: Door thickness + 17 mm in use of INSET type (Door thickness + 12 mm in use of INSET type of GH160 or G170 hinge)

### Recommended Screws

- Size 3.5 tapping screw or wood screw (do not use countersunk head screws)

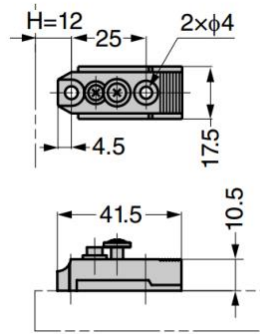

Part No.	Material	Finish
G100-03	Zinc Alloy (ZDC)	Satin Chrome

## G100-03A Mounting Plate

### Features

- Overlay adjustable
- Standard height: 0 mm
- Value of H: Door thickness + 17 mm in use of INSET type (Door thickness + 12 mm in use of INSET type of GH160 or G170 hinge)

### Recommended Screws

- Size 3.5 tapping screw or wood screw (do not use countersunk head screws)

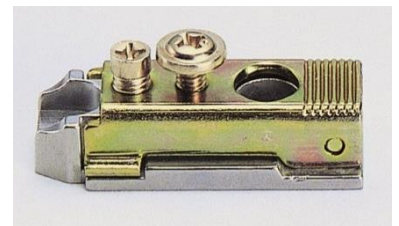
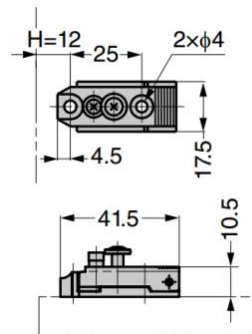

Part No.	Material	Finish
G100-03A	Zinc Alloy (ZDC) / Steel	Nickel / Coloured Zinc Chromate

## G100-P3A Mounting Plate

### Features

- Overlay adjustable
- Standard height: 0 mm
- Value of H: Door thickness + 17 mm in use of INSET type (Door thickness + 12 mm in use of INSET type of GH160 or G170 hinge)

### Recommended Screws

- Size 3.5 tapping screw or wood screw (do not use countersunk head screws)

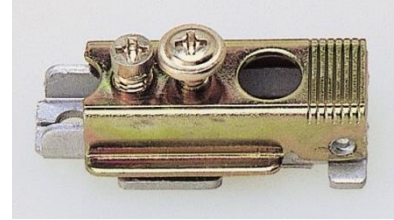
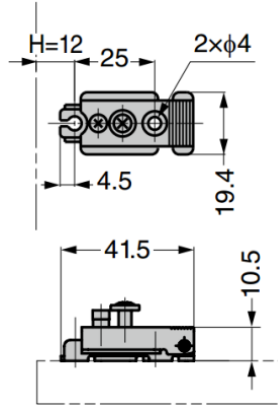

Part No.	Material	Finish
G100-P3A	Steel	Satin Chrome / Coloured Zinc Chromate

## G100-02-30 Mounting Plate

### Features

- Standard height: 0 mm
- Value of H: Door thickness + 17 mm in use of INSET type (Door thickness + 12 mm in use of INSET type of GH160 or G170 hinge)

### Recommended Screws

- Size 3.5 tapping screw or wood screw (do not use countersunk head screws)

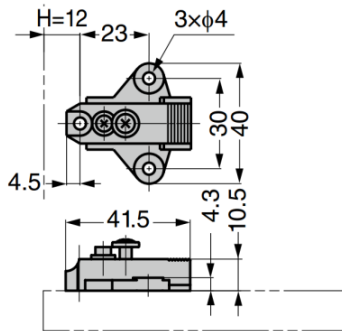

Part No.	Material	Colour
G100-02-30	PA	Ivory

## G100-04-30 Mounting Plate

### Features

- Standard height: 0 mm
- Value of H: Door thickness + 17 mm in use of INSET type (Door thickness + 12 mm in use of INSET type of GH160 or G170 hinge)

### Recommended Screws

- Size 3.5 tapping screw or wood screw (do not use countersunk head screws)

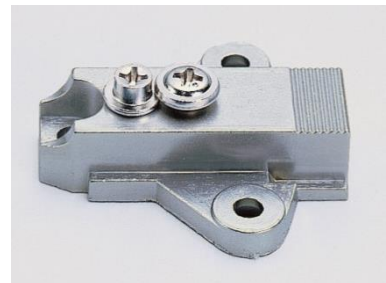
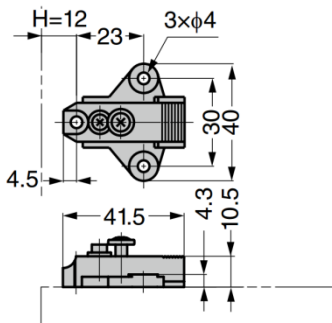

Part No.	Material	Finish
G100-04-30	Zinc Alloy (ZDC)	Satin Chrome

## G100-02A-30 Mounting Plate

### Features

- Overlay adjustable
- Standard height: 0 mm
- Value of H: Door thickness + 17 mm in use of INSET type (Door thickness + 12 mm in use of INSET type of GH160 or G170 hinge)

### Recommended Screws

- Size 3.5 tapping screw or wood screw (do not use countersunk head screws)

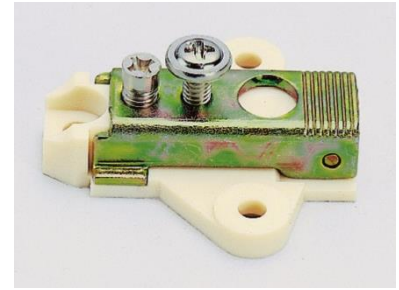
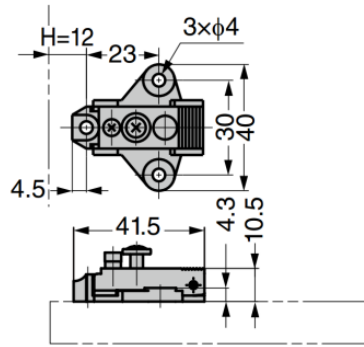

Part No.	Material	Finish / Colour
G100-02A-30	PA / Steel	Ivory / Coloured Zinc Chromate

## G100-04A-30 Mounting Plate

### Features

- Overlay adjustable
- Standard height: 0 mm
- Value of H: Door thickness + 17 mm in use of INSET type (Door thickness + 12 mm in use of INSET type of GH160 or G170 hinge)

### Recommended Screws

- Size 3.5 tapping screw or wood screw (do not use countersunk head screws)

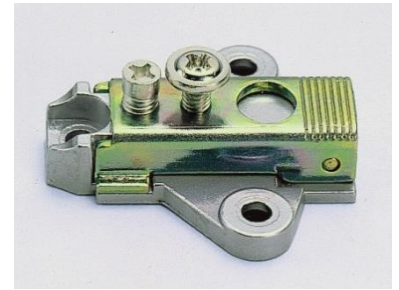
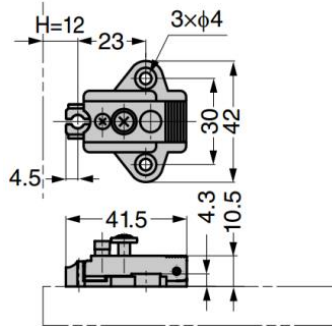

Part No.	Material	Finish
G100-04A-30	Zinc Alloy (ZDC) / Steel	Satin Chrome / Coloured Zinc Chromate

## G100-P4A-30 Mounting Plate

### Features

- Overlay adjustable
- Standard height: 0 mm
- Value of H: Door thickness + 17 mm in use of INSET type (Door thickness + 12 mm in use of INSET type of GH160 or G170 hinge)

### Recommended Screws

- Size 3.5 tapping screw or wood screw (do not use countersunk head screws)

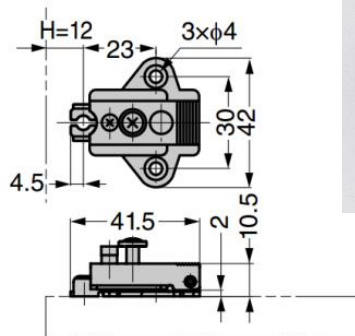

Part No.	Material	Finish
G100-P4A-30	Steel	Satin Chrome / Coloured Zinc Chromate

## G100-04W-30 Mounting Plate

### Features

- Height adjustable ( $\pm 1.5$ )
- Standard height: 0 mm
- Value of H: Door thickness + 17 mm in use of INSET type (Door thickness + 12 mm in use of INSET type of GH160 or G170 hinge)

### Notes

- When using a concealed hinge with wide angle opening, vertical adjustment screw is difficult to adjust

### Recommended Screws

- Size 3.5 tapping screw or wood screw (do not use countersunk head screws)

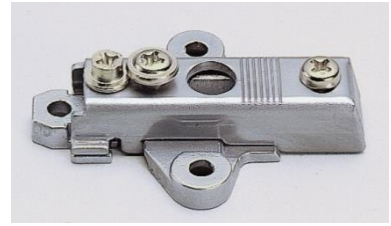
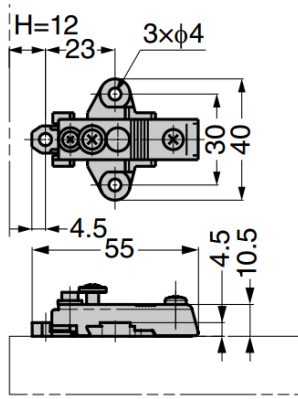

Part No.	Material	Finish
G100-04W-30	Zinc Alloy (ZDC) / Steel	Satin Chrome

## G100-04A-W-30 Mounting Plate

### Features

- Height adjustable ( $\pm 1.5$ )
- Standard height: 0 mm
- Value of H: Door thickness + 17 mm in use of INSET type (Door thickness + 12 mm in use of INSET type of GH160 or G170 hinge)

### Recommended Screws

- Size 3.5 tapping screw or wood screw (do not use countersunk head screws)

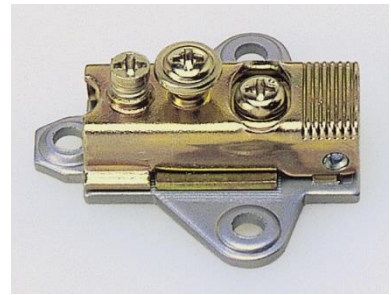
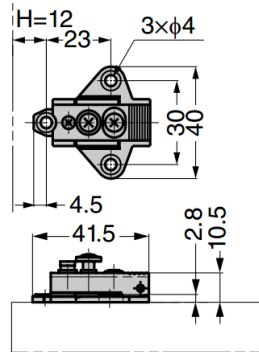

Part No.	Material	Finish
G100-04A-W-30	Steel	Satin Chrome / Coloured Zinc Chromate

## G100-04A-W-30-2 Mounting Plate

### Features

- Overlay and height adjustable ( $\pm 1.5$ )
- Height: 2 mm
- Used to make overlay 2 mm smaller
- Value of H: Door thickness + 17 mm in use of INSET type (Door thickness + 12 mm in use of INSET type of GH160 or G170 hinge)

### Recommended Screws

- Size 3.5 tapping screw or wood screw (do not use countersunk head screws)

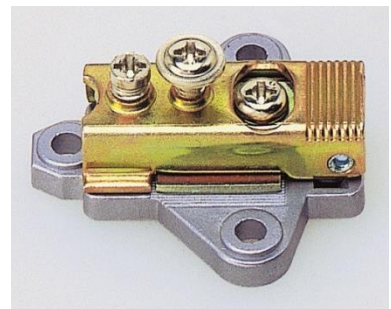
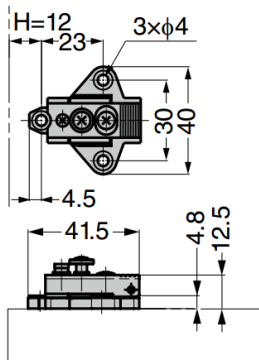

Part No.	Material	Finish
G100-04A-W-30-2	Zinc Alloy (ZDC) / Steel	Satin Chrome / Coloured Zinc Chromate

## G100-04A-32-3 Mounting Plate

### Features

- Overlay adjustable
- Height: 3 mm
- Used to make overlay 3 mm smaller
- Value of H: Door thickness + 17 mm in use of INSET type (Door thickness + 12 mm in use of INSET type of GH160 or G170 hinge)

### Recommended Screws

- Size 3.5 tapping screw or wood screw (do not use countersunk head screws)

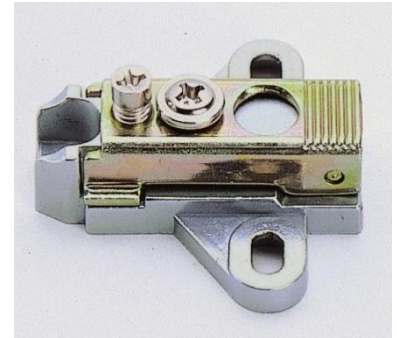
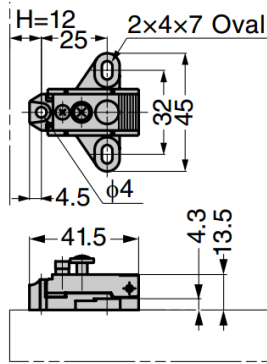

Part No.	Material	Finish
G100-04A-32-3	Zinc Alloy (ZDC) / Steel	Satin Chrome / Coloured Zinc Chromate

## G100-04A-W-32 Mounting Plate

### Features

- Overlay and height adjustable ( $\pm 1.5$ )
- Standard height: 0 mm
- Value of H: Door thickness + 17 mm in use of INSET type (Door thickness + 12 mm in use of INSET type of GH160 or G170 hinge)

### Recommended Screws

- Size 3.5 tapping screw or wood screw (do not use countersunk head screws)

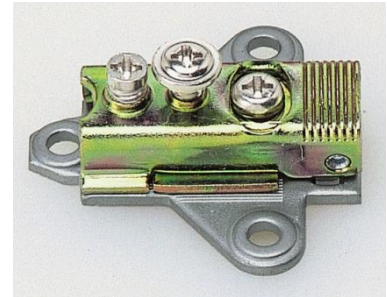
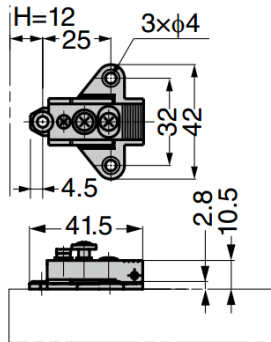

Part No.	Material	Finish
G100-04A-W-32	Steel	Satin Chrome / Coloured Zinc Chromate

## G100-06 Mounting Plate

### Features

- Standard height: 0 mm
- Value of H: Door thickness + 24 mm in use of INSET type (Door thickness + 19 mm in use of INSET type of GH160 or G170 hinge)

### Recommended Screws

- Size 3.1 countersunk head screw

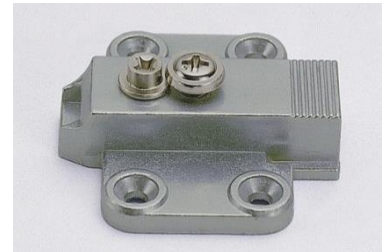
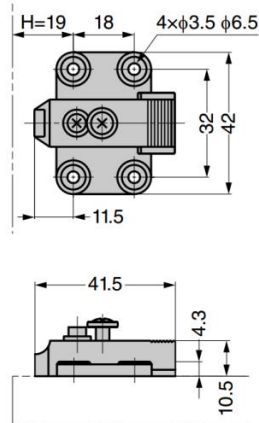

Part No.	Material	Finish
G100-06	Zinc Alloy (ZDC)	Satin Chrome

## G100-06A Mounting Plate

### Features

- Overlay adjustable
- Standard height: 0 mm
- Value of H: Door thickness + 24 mm in use of INSET type (Door thickness + 19 mm in use of INSET type of GH160 or G170 hinge)

### Recommended Screws

- Size 3.5 tapping screw or wood screw (do not use countersunk head screws)

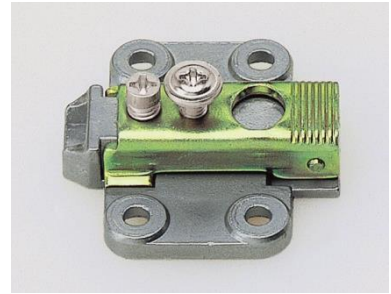
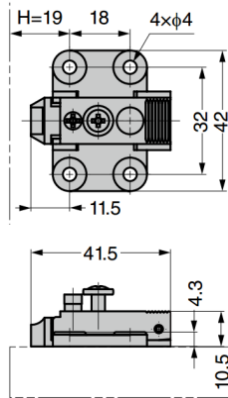

Part No.	Material	Finish
G100-06A	Zinc Alloy (ZDC) / Steel	Satin Chrome / Coloured Zinc Chromate

## G100-P6 Mounting Plate

### Features

- Standard height: 0 mm
- Value of H: Door thickness + 24 mm in use of INSET type (Door thickness + 19 mm in use of INSET type of GH160 or G170 hinge)

### Recommended Screws

- Size 3.1 countersunk head screw

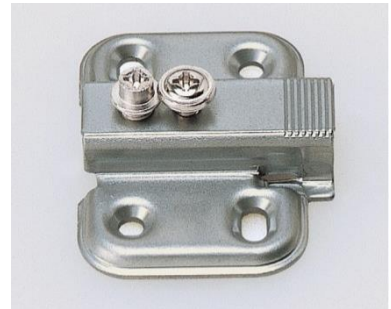
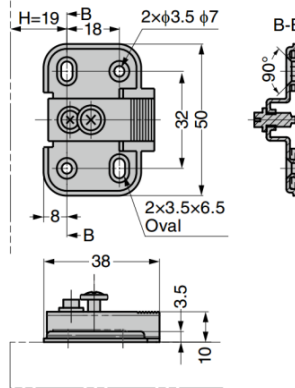

Part No.	Material	Finish
G100-P6	Steel	Satin Chrome

## G100-06AW Mounting Plate

### Features

- Overlay and height adjustable ( $\pm 1.5$ )
- Standard height: 0 mm
- Value of H: Door thickness + 24 mm in use of INSET type (Door thickness + 19 mm in use of INSET type of GH160 or G170 hinge)

### Recommended Screws

- Size 3.5 tapping screw or wood screw (do not use countersunk head screws)

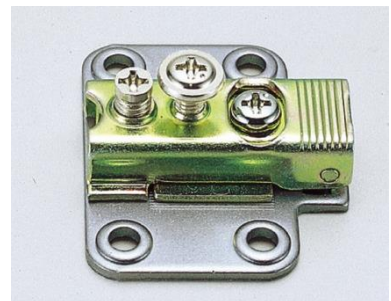
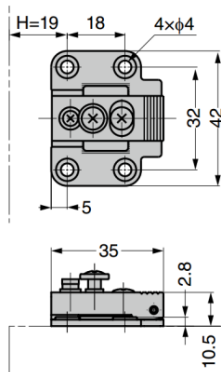

Part No.	Material	Finish
G100-06AW	Steel	Satin Chrome / Coloured Zinc Chromate

## G100-DP2 Spacer for G100 Series Mounting Plate

2mm thickness

### Features

- Used to make overlay 2mm smaller

### Use with the Following Mounting Plates

G100-01	G100-03
G100-03A	G100-P3A
G100-P3A-SUS304B	



Part No.	Material	Colour
<b>G100-DP2</b>	PA	Ivory

## G100-DP2-30 Spacer for G100 Series Mounting Plate

2mm thickness

### Features

- Used to make overlay 2mm smaller

### Use with the Following Mounting Plates

G100-02-30	G100-02A-30
G100-04-30	G100-04A-30
G100-04W-30	G100-P4A-30
G100-04A-W-30	G100-04A-W-30-2
G100-P4A-30-SUS304B	



Part No.	Material	Colour
<b>G100-DP2-30</b>	PA	Ivory

## G100-DP2-32 Spacer for G100 Series Mounting Plate

2mm thickness

### Features

- Used to make overlay 2mm smaller

### Use with the Following Mounting Plates

G100-04A-32-3	G100-04A-W-32
G100-P4A-32-SUS304B	



Part No.	Material	Colour
<b>G100-DP2-32</b>	PA	Ivory

## G100-DP2-06 Spacer for G100 Series Mounting Plate

2mm thickness

### Features

- Used to make overlay 2mm smaller

### Notes

- When used for G100-06AW, it may partially protrude

### Use with the Following Mounting Plates

G100-06	G100-06AW
G100-06A	



Part No.	Material	Colour
<b>G100-DP2-06</b>	PA	Ivory

## Jig For Mounting Plate

For wooden overlay door

Use with the Following Mounting Plates	
G100-01	G100-03
G100-03A	G100-02-30
G100-04-30	G100-02A-30
G100-04A-30	G100-04A-W-30
G100-04A-W-30-3	G100-04A-32-3
G100-04A-W-32	

### Notes

- Cannot be used for inset type mounting plates



### [How to Install]

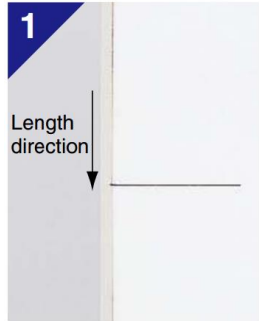

- Draw a line at the centre of the mounting plate installation position (length direction) on side board etc. If you want to erase the line later, drawing on the edge of side board is recommended.



- Align the V-groove of the jig with the line.



- Insert the mounting plate into the jig for correct installation position. Optionally, insert the mounting plate into the jig and then align with the line (in reverse order of ② and ③).



- Hold the jig while fixing the mounting plate with a screw.

### [Other Examples]



- Can also be used with mounting plates designed for system type.



- Mark the holes for easy installation.

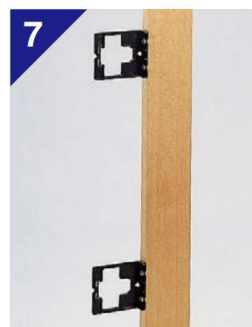

- Attach the jig to a bar when installing several mounting plates at the same time.



- The bar will help you decide the correct distance between the plates.

## Examples of Installation to Sheet Metal (Brackets not included)

Concealed hinges can also be used for metal cabinets

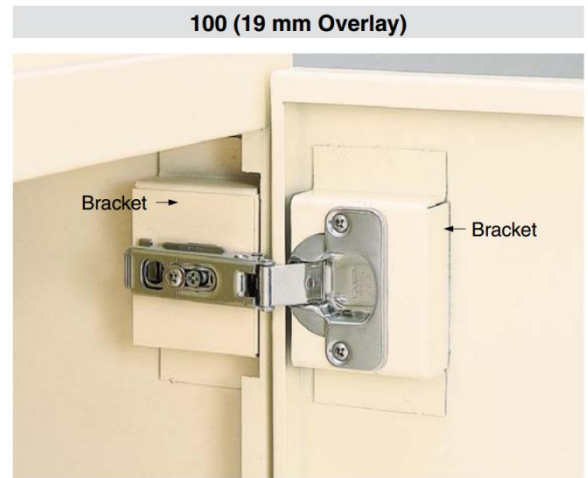

### [Bracket Installation]

Refer to this example and install brackets to the inner side of door and cabinet side board.

Customer should provide brackets.

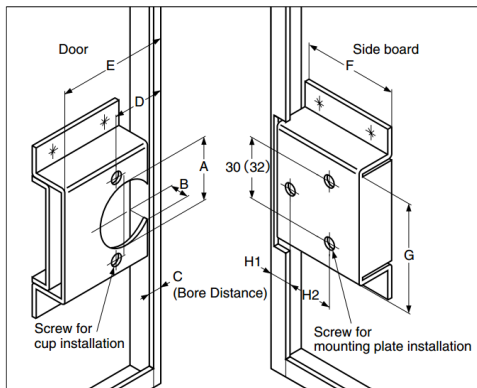

Size A: Cup diameter ( $\phi 26$ ,  $\phi 35$ , or  $\phi 40$ )

Size B: Bore depth (Be sure to support cup bottom)

Size C: Bore distance

Size D: Distance from door edge to cup mounting screw

Size E: More than distance from door edge to tip of cup flange.

● For details, refer to the content page of each hinge.

Size F: More than total length of mounting plate.

Size G: More than width of mounting plate.

Size H<sub>1</sub>, H<sub>2</sub>: Installation position size from edge of mounting plate.

● For details, refer to the content page of the mounting plate of hinge used.

### Bracket for Mounting Plate Installation



### Bracket for Cup Installation

